

Keysight Technologies

J7211A/B/C Attenuation Control Units

DC to 6 GHz, DC to 18 GHz, DC to 26.5 GHz

0 to 101/121 dB attenuation range, 1 dB step size

Technical Overview

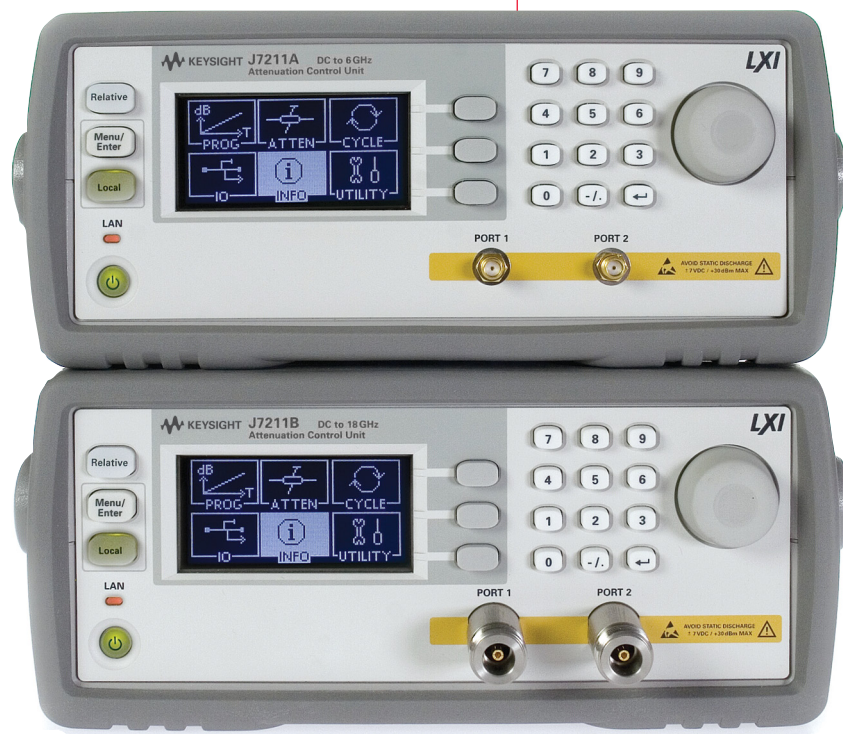

Key Features

- 0.03 dB insertion loss repeatability per section for the entire 5 million cycles ensures accuracy and reduces calibration intervals
- Excellent attenuation accuracy and flatness ensure precise measurements
- Keysight Technologies, Inc. calibrated data correction displays the exact corrected attenuation value
- Attenuation sweep function enables the selection of application-specific dwell time and attenuation values
- LXI Class C compliance provides GPIB, USB and LAN connectivity for easy remote integration
- Relative attenuation step function allows attenuation to be set relative to any value

Description

Keysight Technologies J7211A/B/C attenuation control units increase efficiency and throughput of benchtop and ATE testing of wireless components. An ideal solution for R&D and manufacturing, these standalone instruments offer a user-defined attenuation sweep function which lets you set the desired attenuation range, step size, number of cycles and attenuation configuration based on your application's requirements. This function, combined with excellent repeatability and accuracy, facilitates the design, validation and manufacture of WiMAX™ and WLAN components; and eases mobile handset base transceiver station (BTS) handover testing.

Exceptional 0.03 dB insertion loss repeatability per section with excellent attenuation accuracy and flatness ensure precise measurements. This reduces calibration intervals which lowers the cost of test for the entire 5 million lifecycle.

Designed in a half-rack, 2 unit high-form factor, the J7211A/B/C are packed with features and functions that are easily accessible via the soft keys and the rotary knob located on the front panel. LXI Class C compliance provides GPIB, USB and LAN connectivity for easy remote control and triggering. Calibration data is stored in the instrument's memory for fast, easy retrieval.

Applications

Mobile receiver sensitivity test

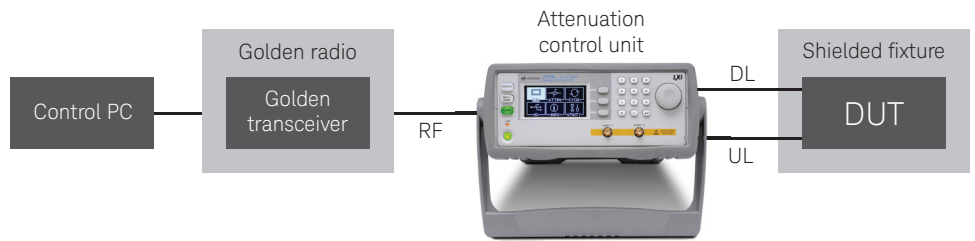

Figure 1. Test setup for mobile receiver sensitivity test using a golden radio

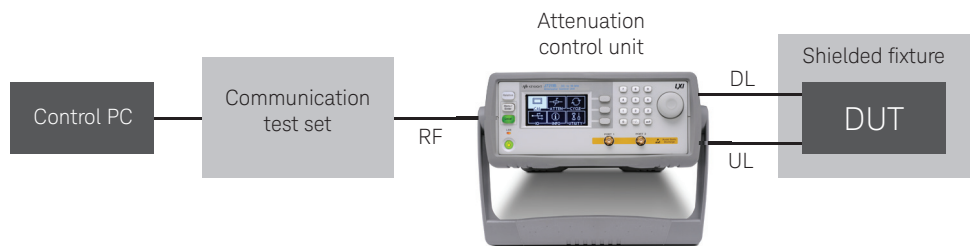

Figure 2. Test setup for mobile receiver sensitivity test using a communication test set

Figure 1 and 2 show test setups for measuring receiver sensitivity. The receiver sensitivity test measures a receiver's performance using known signal conditions including: modulation and coding type, SNR, and power input levels. Using the specified conditions, receivers must be able to decode data bits with a specified bit error rate (BER) at different input power levels.

Many manufacturers have opted to use costly, high-end signal generators to get accurate power levels across a wide range. However, although these instruments usually provide > 0.4 dB accuracy, at lower power levels where receiver sensitivity tests are being carried out, the accuracy is often ± 1 dB. The power level of the test signal is important as a small change in the input power level can greatly affect the BER performance of the receivers. For more information, refer to the application note Power Accuracy in Receiver Sensitivity Test, literature number 5989-8768EN.

Figures 1 and 2 show you how to use an external attenuator to get fast and accurate power levels for mobile receiver sensitivity test. The J7211A/B/C attenuation control units are used with a signal generator to provide extremely accurate power measurements. Calibration can be done at one relatively high power level, for instance 0 dBm, and then the signal level is stepped down through the attenuation control unit. In this way, the power level from the source can be kept at a constant eliminating power level linearity problems in the test signal. Corrected attenuation data is provided at each attenuation level of the attenuation control unit's frequency range (from DC to 6/18/26.5 GHz), this gives you the exact input power level for each DUT. This also ensures test signal accuracy at very low power levels where a slight difference in the input test signal level has an adverse effect on DUT performance. The attenuation control unit's superb repeatability of 0.03 dB per section ensures the accuracy and stability of the input power.

Generally, this method improves amplitude accuracy, reduces the output noise floor of the test stimulus, and ensures a consistent and linear performance of the input signal regardless of its level. Because the packet error rate (PER) and frame error rate (FER) are highly sensitive to the input power level, this will have high impact on the yield of the receiver test.

WiMAX 1st adjacent channel interference

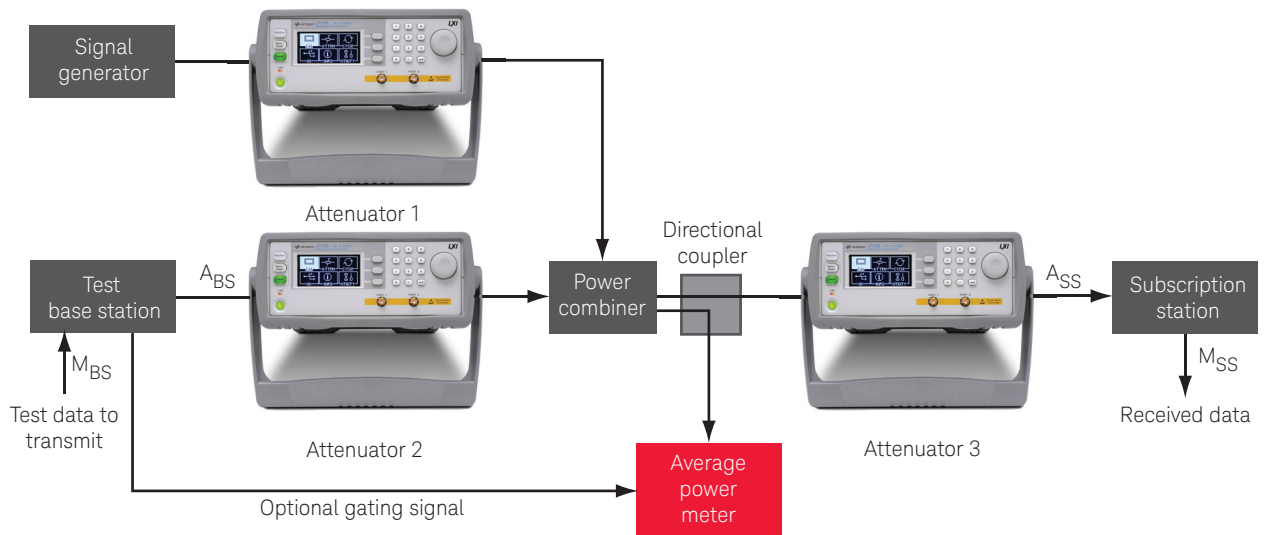

Figure 3. Test setup for 1st adjacent channel interference

Figure 3 shows the test setup for WiMAX 1st adjacent channel interference. The adjacent channel interference test measures the signal in the adjacent channel to ensure that the receiver meets the specifications shown in Tables 1 and 2.

A connection between the test base station (BS) and the subscriber station (SS) is set up as shown in Figure 3. Attenuators 1 and 2 are used to adjust the signal level between the useful and interfering signals. Attenuator 3 is used to adjust the absolute signal level at the receiver and can be held at a constant value of 10 dB. The signal generator transmits a signal on the first adjacent channel that is similar to the useful signal. The losses for the coupler and the connecting waveguides are measured and the attenuators are calibrated. When measuring the power, you need to take into account the effect of the coupler, the losses and the duty cycle.

After the system is calibrated, set attenuator 2 to its maximum value and turn the signal generator off. The downlink QPSK data is generated and attenuator 1 is adjusted for BER = 10^{-3} . See Tables 1 and 2. Increase the signal power by 3 dB and measure the power. Switch the signal generator on and decrease the attenuator 2 until BER = 10^{-3} is achieved. Then turn off the test BS and measure the power of the interfering signal. The procedure is repeated for the other modulation schemes, 1 dB degradation and BER = 10^{-6} .

Table 1. 1st adjacent channel interference BER = 10^{-3}

	1 dB degradation	3 dB degradation
QPSK	-5 dB	-9 dB
16-QAM	+2 dB	-2 dB
64-QAM	+9 dB	+5 dB

Table 2. 1st adjacent channel interference BER = 10^{-6}

	1 dB degradation	3 dB degradation
QPSK	-1 dB	-5 dB
16-QAM	+6 dB	+2 dB
64-QAM	+13 dB	+9 dB

Specifications describe the instrument's warranted performance. Supplemental and typical characteristics are intended to provide information useful in applying the instrument by giving typical, but not warranted performance parameters.

Specifications

Product model	J7211A	J7211B	J7211C
Frequency range	DC to 6 GHz	DC to 18 GHz	DC to 26.5 GHz
Attenuation range	0 to 121 dB	0 to 121 dB	0 to 101 dB
Attenuation step size	1, 5 and 10 dB	1, 5 and 10 dB	1, 5 and 10 dB
Insertion loss (at 0 dB)	2.5 dB	DC to 6 GHz: 2.5 dB 6 to 18 GHz: 5.0 dB	DC to 6 GHz: 2.5 dB 6 to 18 GHz: 4.0 dB 18 to 26.5 GHz: 5.0 dB
Return loss (VSWR)	14 dB (1.50)	DC to 6 GHz: 14 dB (1.50) 6 to 18 GHz: 10 dB (1.90)	DC to 6 GHz: 16 dB (1.35) 6 to 18 GHz: 11 dB (1.78) 18 to 26.5 GHz: 7 dB (2.61)
RF repeatability per section	0.03 dB	0.03 dB	0.05 dB
Maximum power input	1 W (+30 dBm)		
Switching speed	20 ms		
Operating life	5 million cycles (guaranteed)		
Connectivity	GPIB, USB, LAN (LXI Class C)		
Connector type	SMA/Type-N	SMA/Type-N	3.5 mm

J7211A/B/C Supplemental Specifications and Characteristics

Supplemental characteristics are intended to provide useful information. They are typical but non-warranted performance parameters.

J7211A/B/C attenuation control units			
Power	100 to 240 Vac, automatic selection, 50/60 Hz		
	50 VA maximum		
	Main supply voltage fluctuations are not exceed 10 percent of the nominal supply voltage		
Connector type	Pin depth specifications		Specifications
	(mm)	(inches)	
Type-N 50 Ω female	4.750 to 5.258	0.187 to 0.207	MIL-C-39012
SMA female	0.000 to -0.254	0.000 to -0.010	MIL-C-39012
3.5 mm female	0.000 to -0.076	0.000 to -0.003	IEEE STD 287 GPC

Attenuation Accuracy

(\pm dB; referenced from 0 dB setting)

J7211A/B			
Attenuation setting for step ranges (dB)	DC to 6 GHz	6 to 18 GHz	
1 to 2	0.3	0.7	
3 to 4	0.4	0.7	
5 to 6	0.5	0.8	
7 to 10	0.6	0.8	
11 to 20	0.7	1.4	
21 to 40	1.2	2	
41 to 60	1.8	2.8	
61 to 80	2.4	3.6	
81 to 100	3	4.4	
101 to 121	3.3	5.3	
J7211C			
Attenuation setting for step ranges (dB)	DC to 6 GHz	6 to 18 GHz	
1 to 2	0.35	0.4	
3 to 6	0.55	0.7	
7 to 10	0.7	0.8	
11 to 20	1.2	1.4	
21 to 40	1.4	1.6	
41 to 60	1.9	2.5	
61 to 80	2.5	2.7	
81 to 101	3.7	4.0	

Additional Functions

Function	Description
Attenuation sweep function	Provides user-defined parameter setting for application-specific testing Key parameter settings: <ul style="list-style-type: none"> – Delay time before START – Attenuation range – Attenuation step size (1 to 10 dB; 1 dB incremental) – Attenuation start, stop and dwell time (100 ms to 10 s; 100 ms incremental) – Number of attenuation cycles (1000 cycles maximum) Forward and backward attenuation cycles
Relative attenuation step function	Enables testing relative to any preset attenuation value
Display of data correction value	Displays correction value for attenuation using stored calibration data

Typical Performance



Figure 4. Keysight J7211A attenuation control unit insertion loss (at 0 dB) versus frequency

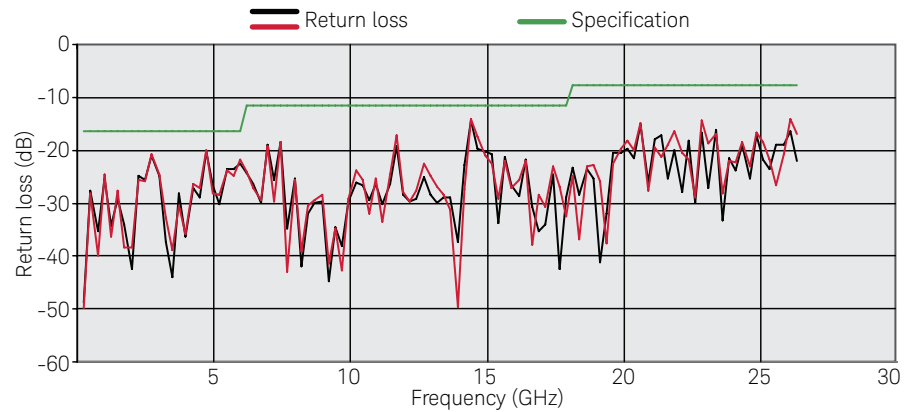

Figure 5. Keysight J7211A attenuation control unit return loss versus frequency

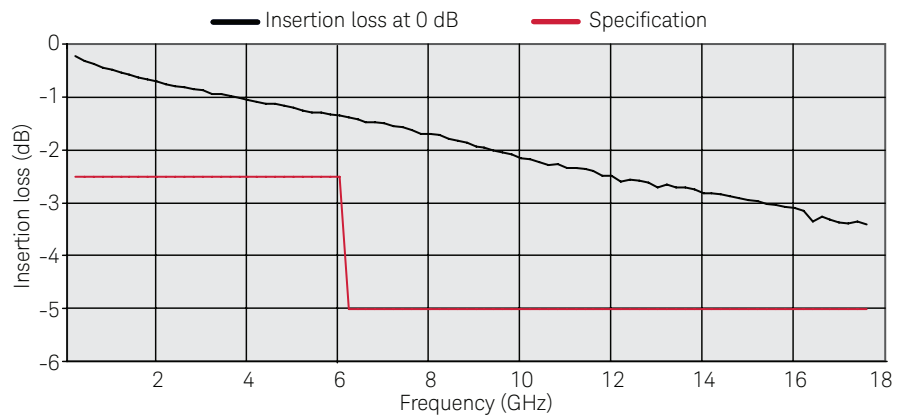

Figure 6. Keysight J7211B attenuation control unit insertion loss (at 0 dB) versus frequency

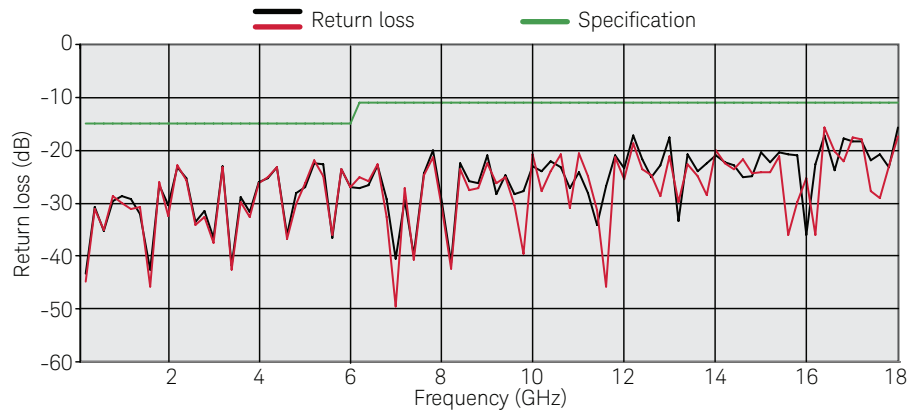

Figure 7. Keysight J7211B attenuation control unit return loss versus frequency

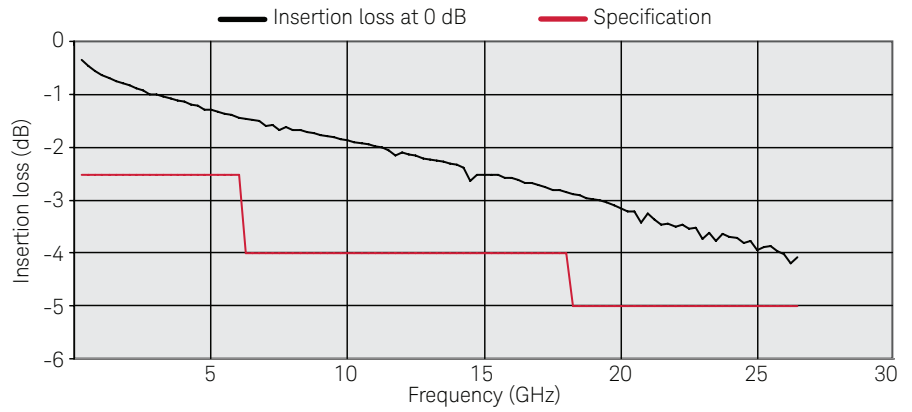

Figure 8. Keysight J7211C attenuation control unit insertion loss (at 0 dB) versus frequency

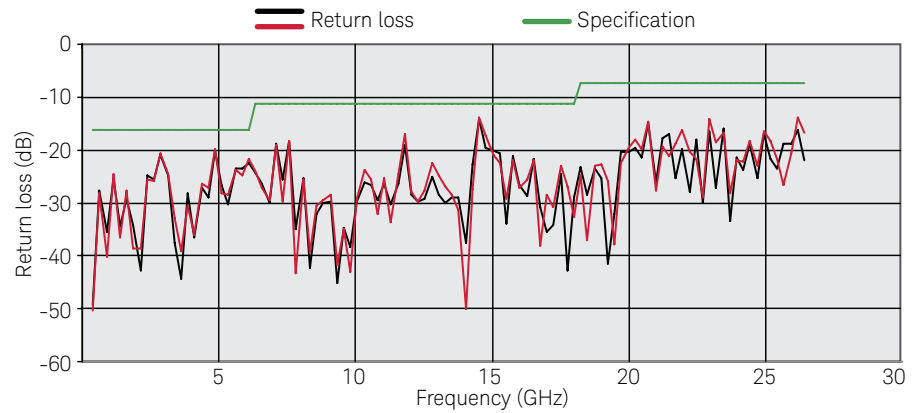

Figure 9. Keysight J7211C attenuation control unit return loss versus frequency

Environmental Specifications

Keysight J7211A/B/C attenuation control units are designed to fully comply with Keysight Technologies' product operating environmental specifications. The following summarizes the environmental specifications for these products.

Temperature	
Operating	0 °C to +50 °C
Storage	-40 °C to +70 °C
Humidity	
Operating	95% RH at 40 °C, 5 days cyclic
Storage	90% RH @ 65 °C, 25 hours
Condensing	95% RH at 40 °C, 5 hours (condensation 15 minutes)
Shock	
End-user handling	Half-sine: 203 ms duration, 60 in/s (1.6 ms) delta-V
Bench handling	Per MIL-PRF-28800F
Functional	Half-sine: 11 ms duration, 30 grms
Transportation	Trapezoidal: 18-22 ms duration, 337 in/s (8.56 ms) delta-V
Vibration	
Operating	Random: 0.21 Grms, 5 to 500 Hz, 10 min/axis
Survival	Random: 2.09 Grms, 5 to 500 Hz, 10 min/axis Swept-sine: 0.5 Grms, 5 to 500 Hz, 10 min/axis
Altitude	
Operating	< 4,572 meters (< 15,000 feet)
Non-operating	< 4,572 meters (< 15,000 feet)

Mechanical Information

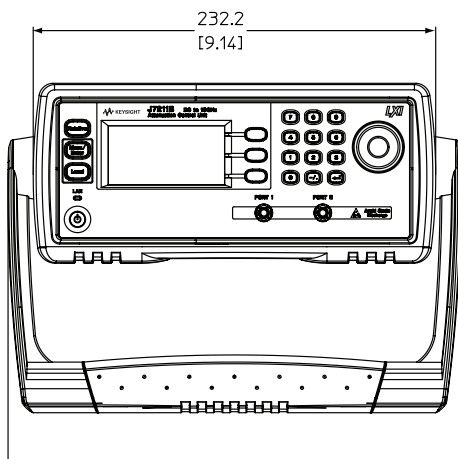

Dimensions are in mm (inches) nominal, unless otherwise specified.

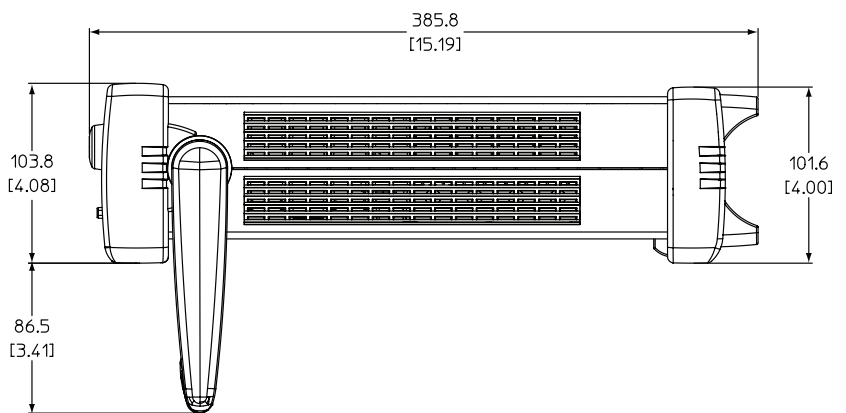

Figure 10. Product dimensions for J7211A/B (SMA connectors)

J7211A/B product dimensions (SMA (f) connectors¹)

Net weight	3.8 kg (8.4 lbs)
Dimension (H x W x D) with handle and rubber bumper	103.8 mm x 232.2 mm x 385.7 mm (4.1 inches x 9.1 inches x 15.2 inches)
Dimension (H x W x D) without handle and rubber bumper	88.3 mm x 212.7 mm x 362.0 mm (3.5 inches x 8.4 inches x 14.2 inches)

1. Only available for J 7211A/B.

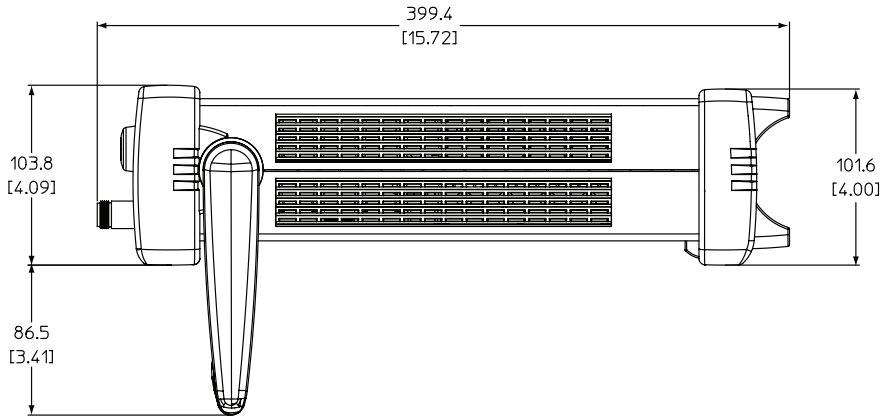
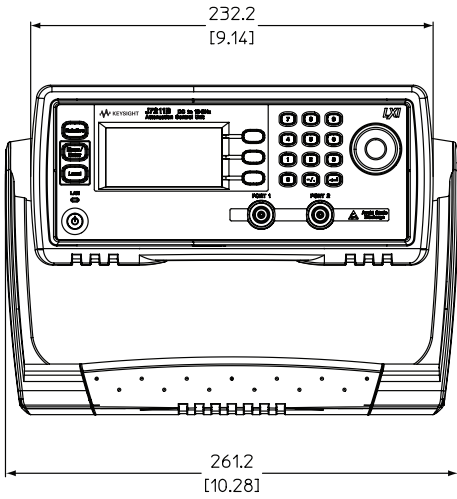

Figure 11. Product dimensions for J7211A/B (Type-N connectors)

J7211A/B product dimensions (Type-N (f) connectors¹)

Net weight	3.8 kg (8.4 lbs)
Dimension (H x W x D) with handle and rubber bumper	103.8 mm x 232.2 mm x 398.4 mm (4.1 inches x 9.1 inches x 15.7 inches)
Dimension (H x W x D) without handle and rubber bumper	88.3 mm x 212.7 mm x 374.7 mm (3.5 inches x 8.4 inches x 14.6 inches)

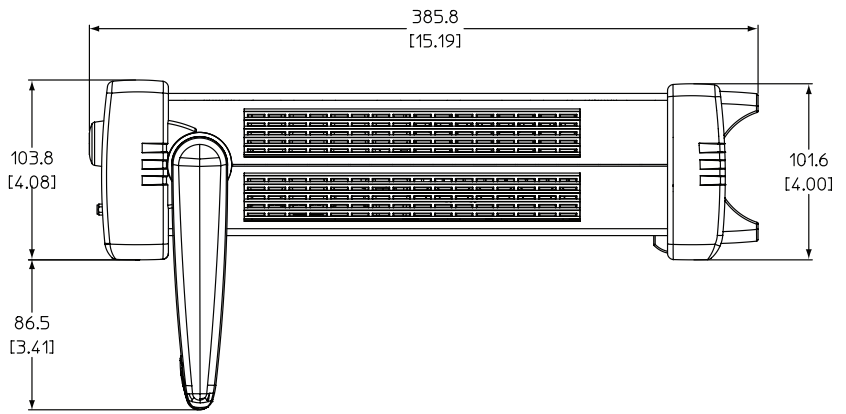
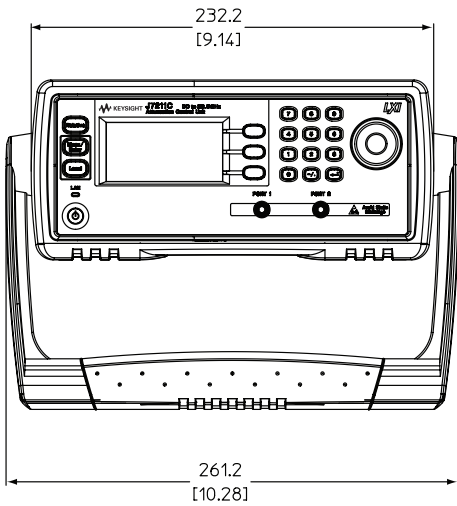

Figure 12. Product dimension for J7211C (3.5 mm connector)

J7211C product dimensions (3.5 mm (f) connector²)

Net weight	3.8 kg (8.4 lbs)
Dimension (H x W x D) with handle and rubber bumper	103.8 mm x 232.2 mm x 385.7 mm (4.1 inches x 9.1 inches x 15.2 inches)
Dimension (H x W x D) without handle and rubber bumper	88.3 mm x 212.7 mm x 362.0 mm (3.5 inches x 8.4 inches x 14.2 inches)

1. Only available for J7211A/B.
2. Only available for J7211C.

Ordering Information

J7211A	Attenuation control unit, DC to 6 GHz, 0 to 121 dB
Option 001	Type-N (f) connector
Option 002	SMA (f) connector
Option UK6	Commercial calibration certificate with test data
J7211B	Attenuation control unit, DC to 6 GHz, 0 to 121 dB
Option 001	Type-N (f) connector
Option 002	SMA (f) connector
Option UK6	Commercial calibration certificate with test data
J7211C¹	Attenuation control unit, DC to 26.5 GHz, 0 to 101 dB
Option UK6	Commercial calibration certificate with test data

1. 3.5 mm (f) connectors only.

Ordering Information

www.keysight.com/find/mta
www.keysight.com/find/J7211

Related Literature

Power Accuracy in Receiver Sensitivity Test, Application Note, literature number 5989-8768EN.

Evolving Since 1939

Our unique combination of hardware, software, services, and people can help you reach your next breakthrough. We are unlocking the future of technology.
 From Hewlett-Packard to Agilent to Keysight.



For more information on Keysight Technologies' products, applications or services, please contact your local Keysight office. The complete list is available at: www.keysight.com/find/contactus

Americas

Canada	(877) 894 4414
Brazil	55 11 3351 7010
Mexico	001 800 254 2440
United States	(800) 829 4444

Asia Pacific

Australia	1 800 629 485
China	800 810 0189
Hong Kong	800 938 693
India	1 800 11 2626
Japan	0120 (421) 345
Korea	080 769 0800
Malaysia	1 800 888 848
Singapore	1 800 375 8100
Taiwan	0800 047 866
Other AP Countries	(65) 6375 8100

Europe & Middle East

Austria	0800 001122
Belgium	0800 58580
Finland	0800 523252
France	0805 980333
Germany	0800 6270999
Ireland	1800 832700
Israel	1 809 343051
Italy	800 599100
Luxembourg	+32 800 58580
Netherlands	0800 0233200
Russia	8800 5009286
Spain	800 000154
Sweden	0200 882255
Switzerland	0800 805353
	Opt. 1 (DE)
	Opt. 2 (FR)
	Opt. 3 (IT)
United Kingdom	0800 0260637

For other unlisted countries:
www.keysight.com/find/contactus
 (BP-9-7-17)

DEKRA Certified
 ISO 9001 Quality Management System

www.keysight.com/go/quality
 Keysight Technologies, Inc.
 DEKRA Certified ISO 9001:2015
 Quality Management System

myKeysight

myKeysight

www.keysight.com/find/mykeysight

A personalized view into the information most relevant to you.

www.keysight.com/find/emt_product_registration

Register your products to get up-to-date product information and find warranty information.

KEYSIGHT SERVICES

Accelerate Technology Adoption.
 Lower costs.

Keysight Services

www.keysight.com/find/service

Keysight Services can help from acquisition to renewal across your instrument's lifecycle. Our comprehensive service offerings—one-stop calibration, repair, asset management, technology refresh, consulting, training and more—helps you improve product quality and lower costs.



Keysight Assurance Plans

www.keysight.com/find/AssurancePlans

Up to ten years of protection and no budgetary surprises to ensure your instruments are operating to specification, so you can rely on accurate measurements.

Keysight Channel Partners

www.keysight.com/find/channelpartners

Get the best of both worlds: Keysight's measurement expertise and product breadth, combined with channel partner convenience.



Unlocking Measurement Insights

This information is subject to change without notice.
 © Keysight Technologies, 2017
 Published in USA, December 1, 2017
 5989-8323EN
www.keysight.com